



# REGIS® CANTILEVER GATES

STANDARD · HEAVY DUTY · INDUSTRIAL



**EAGLE FENCE**  
★ DISTRIBUTING LLC ★  
efdistribution.com

**BEAUTY · STRENGTH · DURABILITY**  
**VIRTUALLY MAINTENANCE FREE**



Gate Stop



Truck Bracket · Post Brace



ASTM F2200 Compliant  
Gap Protector  
(Included with Gate)



# CANTILEVER GATES

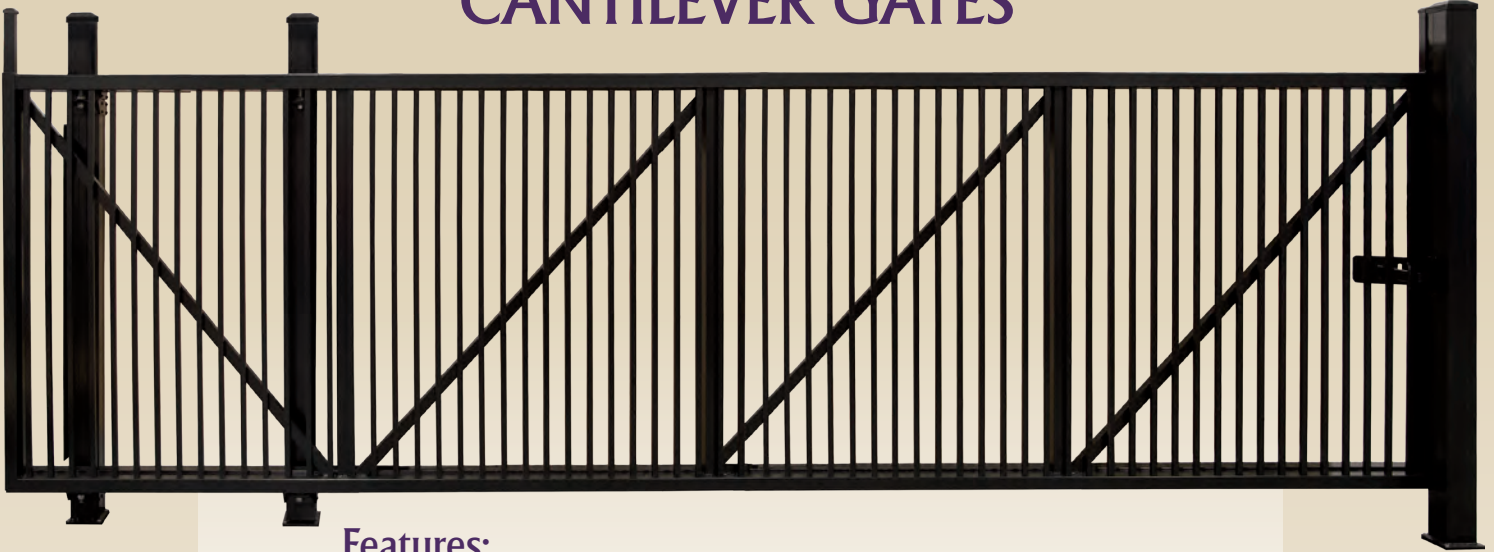

## Features:

- Available in 48", 60", and 72" Heights
- Gates are Welded
- Standard Duty Gates Available in 12', 14', and 16' Single Gate Opening Widths
- Heavy Duty Gates Available in 18', 20', and 22' Gate Opening Widths
- Industrial Duty Gates Available in 24', 26', 28', 30' and 32' Gate Opening Widths
- Double Picket Gates Meet ASTM F2200 and UL-325 Spacing Requirements
- Verified AAMA 2604 Compliant Powder Coated (Upgrade Option AAMA 2605)
- Available in 12 Standard Colors

# CUSTOM GATES AVAILABLE



# REGIS<sup>®</sup> CANTILEVER GATES

## 2 Rail Frame Only Gate

- Available in 48", 60", and 72" heights
- Standard Duty available in 12', 14', and 16' single gate opening widths
- Heavy Duty available in 18', 20', and 22' gate opening widths
- Industrial available in 24', 26', 28', 30', and 32' gate opening widths
- Cantilever Frame Only gates will **NOT** meet ASTM F2200 and UL-325 spacing requirements for motorized gates.
- Aluminum mesh sheets may be attached to gate face & adjacent fence panels to meet ASTM F2200 and UL-325 spacing requirements.



2 Rail Frame Only Gate

## 2 Rail 3/4" Picket (Standard Spacing) Universal or Spear Style

- Available in 48", 60", and 72" heights
- Standard Duty available in 12', 14', and 16' single gate opening widths
- Heavy Duty available in 18', 20', and 22' gate opening widths
- Industrial available in 24', 26', 28', 30', and 32' gate opening widths
- Cantilever gates with standard picket spacing will **NOT** meet ASTM F2200 and UL-325 spacing requirements for motorized gates.
- Aluminum mesh sheets may be attached to gate face & adjacent fence panels to meet ASTM F2200 and UL-325 spacing requirements.



2 Rail 3/4" Picket (Standard Spacing)

## 2 Rail 3/4" Double Picket Universal or Spear Style

- Available in 48", 60", and 72" heights
- Standard Duty available in 12', 14', and 16' single gate opening widths
- Heavy Duty available in 18', 20', and 22' gate opening widths
- Industrial available in 24', 26', 28', 30', and 32' gate opening widths
- Cantilever gates with double picket spacing meets ASTM F2200 and UL-325 spacing requirements for motorized gates.
- Adjacent fence must meet ASTM F2200 and UL325 spacing requirements for motorized gate application.

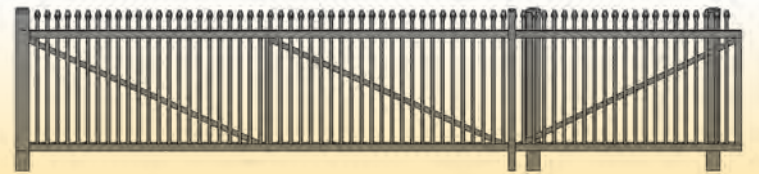

2 Rail 3/4" Double Picket

## 2 Rail 1" Picket (Standard Spacing) Universal or Spear Style

- Available in 48", 60", and 72" heights
- Standard Duty available in 12', 14', and 16' single gate opening widths
- Heavy Duty available in 18', 20', and 22' gate opening widths
- Industrial available in 24', 26', 28', 30', and 32' gate opening widths
- Cantilever gates with standard picket spacing will **NOT** meet ASTM F2200 and UL-325 spacing requirements for motorized gates.
- Aluminum mesh sheets may be attached to gate face & adjacent fence panels to meet ASTM F2200 and UL-325 spacing requirements.

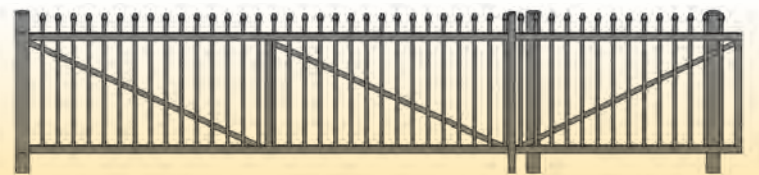

2 Rail 1" Picket (Standard Spacing)

## 2 Rail 1" Double Picket Universal or Spear Style

- Available in 48", 60", and 72" heights
- Standard Duty available in 12', 14', and 16' single gate opening widths
- Heavy Duty available in 18', 20', and 22' gate opening widths
- Industrial available in 24', 26', 28', 30', and 32' gate opening widths
- Cantilever gates with double picket spacing will meet ASTM F2200 and UL-325 spacing requirements for motorized gates.
- Adjacent fence must meet ASTM F2200 and UL325 spacing requirements for motorized gate application.

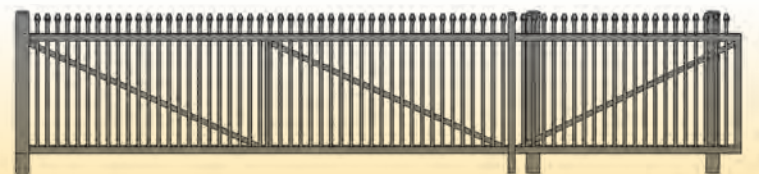

2 Rail 1" Double Picket

*Note For All: Additional rails, arching or special picket spacing requires a special quote from DSI Technical Services.*

# CANTILEVER GATE HARDWARE

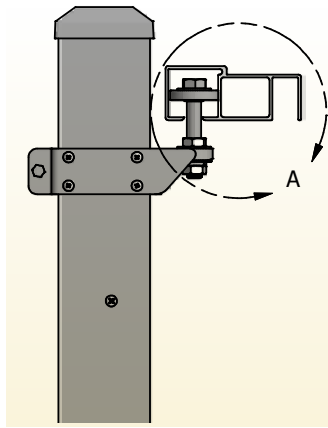

## Standard Cantilever

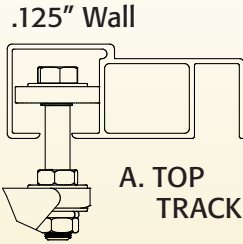

## Heavy Duty Cantilever

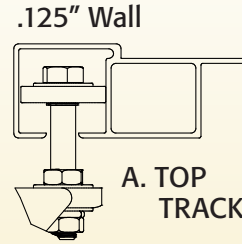

## Industrial Cantilever

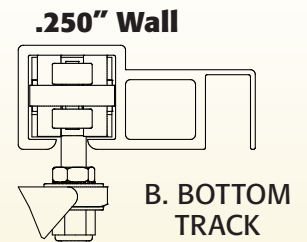
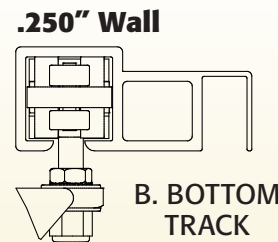
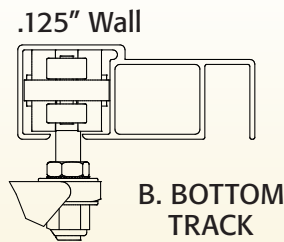
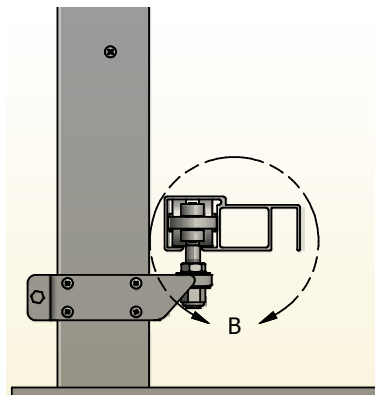
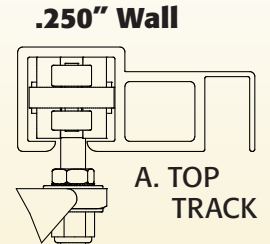

Standard Example Shown Above

## Standard Cantilever

12 ft. - 16 ft. Single Gate Openings  
Standard Top Track with 2 Guide Rollers  
Standard Bottom Track with 2 Trucks  
4" Stabilizing Posts up to 72" Tall  
6" Stabilizing Posts over 72" Tall

## Heavy Duty Cantilever

Over 16 ft. - 22 ft. Single Gate Openings  
Standard Top Track with 2 Guide Rollers  
Heavy Duty Bottom Track with 2 Trucks  
4" Stabilizing Posts for Openings  
over 16' to 20' wide and up to 72" Tall  
6" Stabilizing Posts for Openings over 20' up to  
22' wide and over 72" Tall

## Industrial Cantilever

Over 22 ft. - 32 ft. Single Gate Openings  
Heavy Duty Top Track with 2 Trucks  
Heavy Duty Bottom Track with 2 Trucks  
6" Stabilizing Posts

## Mounting Hardware

Cantilever Truck with Bracket for 4" Square Post  
Cantilever Truck with Bracket for 6" Square Post  
Cantilever Truck (no bracket)\*  
Cantilever Guide Roller with Bracket for 4" Square Post  
Cantilever Guide Roller with Bracket for 6" Square Post  
Cantilever Guide Roller (no bracket)\*

## 4" Square Aluminum Posts

4" x 78" Blank Post  
4" x 90" Blank Post  
4" x 102" Blank Post  
4" x 120" Blank Post  
Flat Post Cap 4" Square  
Ball Post Cap 4" Square

## 6" Square Aluminum Posts

6" x 96" Blank Post  
6" x 108" Blank Post  
6" x 120" Blank Post  
Flat Post Cap 6" Square

## Post Hardware

Post Deflector  
Gate Stop  
Post Brace  
Lock Bar (for non-motorized gates only)

## Aluminum Mesh

Powder Coated Aluminum Mesh (48" x 96" sheet).  
Mounting hardware included.

\*Trucks and Guide Rollers are to be purchased with brackets unless gate is being installed with round posts.



# POWDER COATING



1

The raw premium-grade aluminum is inspected to be free of blemishes and is not exposed to the outdoor elements.



2

The product enters a heated acidic cleaning stage to remove extrusion debris and fabrication oils.



3-6

**CLEAN:** City water rinse  
**CLEANER:** Recycling reverse osmosis water rinse  
**CLEANTEST:** Pure reverse osmosis water rinse  
**SEALER:** Dried-in-place aluminum sealer



7-8

A 200 MPH air blast removes water drops from the pre-treated aluminum. A convection oven completes the dry-off process.



9

Powder is applied with 18 automated and 2 manual spray guns. Compressed process air is dried to -35°F Dew Point for superior adhesion.



10

The powder coating is then bonded and adhered to the aluminum sub-straight in a 400 degree cure stage.



The powder coating application booth produces zero VOC emissions. Powder is stored and applied in a climate controlled positive pressure environmental room. Ten pre-treat system titration checks twice per shift maintain system parameters and ten QC checks are completed every hour on product coming off the powder-coating line. Parts are not touched by human hands during the pre-treat, dry-off, application and cure process to maintain ultimate cleanliness of powder-coated parts.



DSI is a PCI 4000 certified and verified AAMA 2604 and AAMA 2605 compliant powder coating applicator. The powder coating process is accredited by the American Architectural Manufacturing Association and the Powder Coating Institute. Our powder coating is custom blended from a Super Durable Polyester TGIC (Triglycidyl Isocyanurate) resin-base, using premium pigmentation to meet AAMA 2604 specifications. Our AAMA 2605 is a fluorocarbon polymer resin system.





# DSI REGIS FAMILY OF PRODUCTS

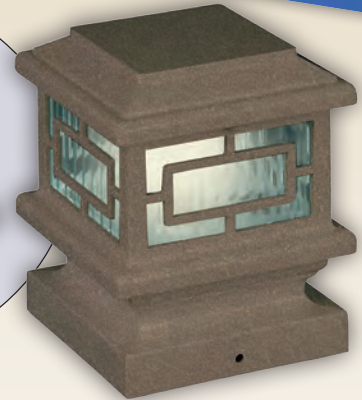
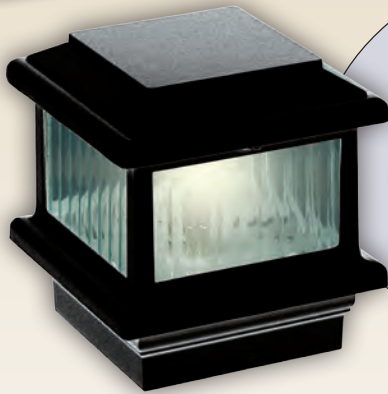
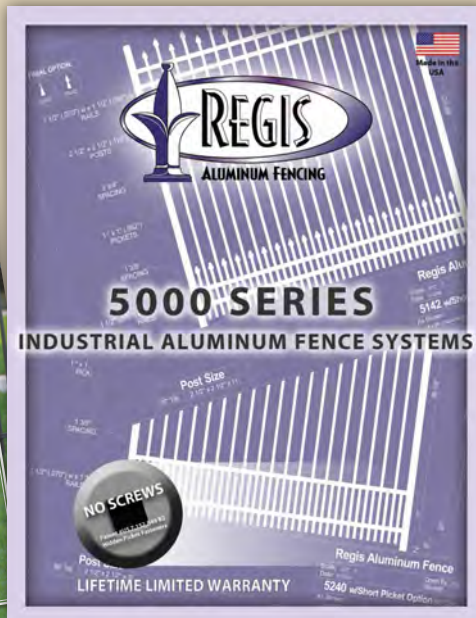
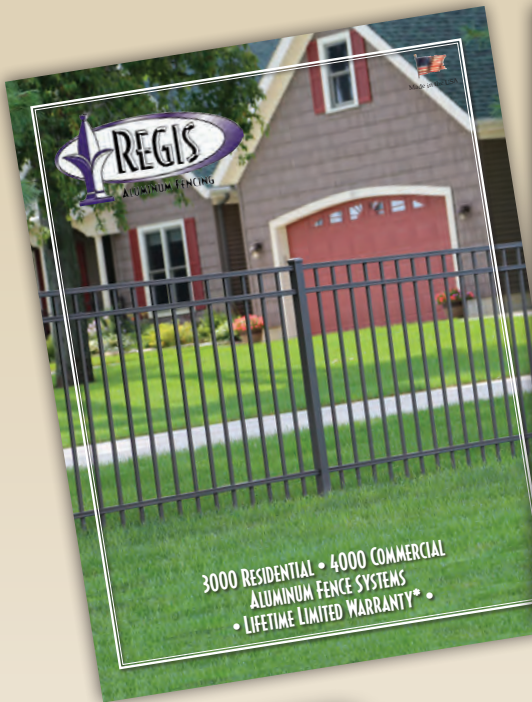

Satin Black

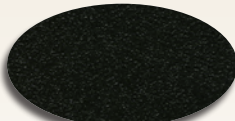

Black Fine Texture



Ninety Bronze



Bronze Fine Texture



Gloss Beige



Gloss White



White Fine Texture



Clay



Speckled Walnut

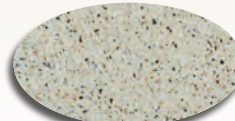

Sandy Shore



Chocolate



Silver



diggerspecialties.com

We have tried to make this catalog comprehensive and factual. We reserve the right to discontinue at any time, without notice, colors, materials, equipment and availability. Since some information may have been updated since the time of printing, we are not responsible for typographical or pictorial errors. Materials shown may vary slightly from actual colors. ©Digger Specialties 2016 SP 06/16 99500